

# pressure limitation valve

## type **SPB 65**

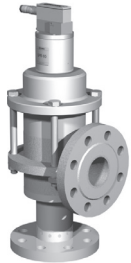

**control valve** proportional  
**pressure range** PN 0-64 bar  
**orifice** DN 65 mm  
**connection** flange  
**function** stepless  
 pressure regulation  
 bypass version

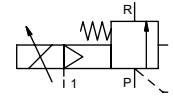

Above stated body materials refer to the valve port connections that get in contact with the media only!

**design** externally controlled with spring return  
**body materials** ① ④  
 ② steel, galvanized ⑤  
 ③ ⑥  
**valve seat** metal on metal  
**seal materials** NBR **FPM**

**details needed for main valve**

- orifice
- port
- pressure regulating range
- flow rate
- media
- media temperature
- ambient temperature

**details needed for proportional valve**

- nominal voltage
- actuation pressure range min/max

**ports** SPB flanges PN 64  
**function** stepless regulation  
**pressure regulation range** bar 5-64  
**Kv value** m<sup>3</sup>/h max. 60  
**media** liquid - highly viscous - contaminated  
**abrasive media**  
**flow direction** P ⇌ R as marked  
**operating time** ms < 400  
**media temperature** °C 0 to +60  
**ambient temperature** °C 0 to +50  
**approvals**  
**mounting**  
**weight** kg 42,6  
**additional equipment**

**general specifications**

**options**

**electrical specifications**

**options**

**nominal voltage** U<sub>B</sub> DC 24 V (max. residual ripple 10%)  
**power consumption** DC < 0,7 A  
**control signals** U<sub>E</sub> 0-10 V (R<sub>E</sub> 10KΩ)  
**protection** IP65 acc. DIN 40 050  
**energized duty rating** ED 100% (observe the connection conditions accordingly)  
**connection** plug with 7 contacts / wire diameter 6-8 mm

**pneumatic specifications**

**options**

**actuation pressure range** bar see actuation pressure-diagram  
**air consumption** DIN ISO 8573-1 grade of compressed air quality 5/4/3  
**control** by 3/2-way proportional valve  
**actuator ports** 1 G 1/8

The valves' technical design is based on media and application requirements. This can lead to deviations from the general specifications shown on the data sheet with regards to the design, sealing materials and characteristics.

If order or application specifications are incomplete or imprecise there exists a risk of an incorrect technical design of the valve for the required application. As a consequence, the physical and / or chemical properties of the materials or seals used, may not be suitable for the intended application.

**connection plan**

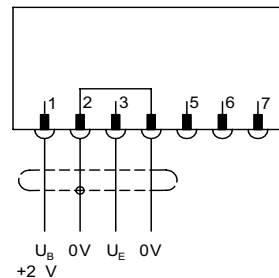

**connection conditions**

When supplying the electrical set point signal to the proportional valve, the actuating air must already be present. (see actuation pressure-diagram)

**position of installation**

arbitrarily, but regulator not downwards

■ specifications not highlighted are standard  
 ■ specifications highlighted in grey are optional

# type SPB 65

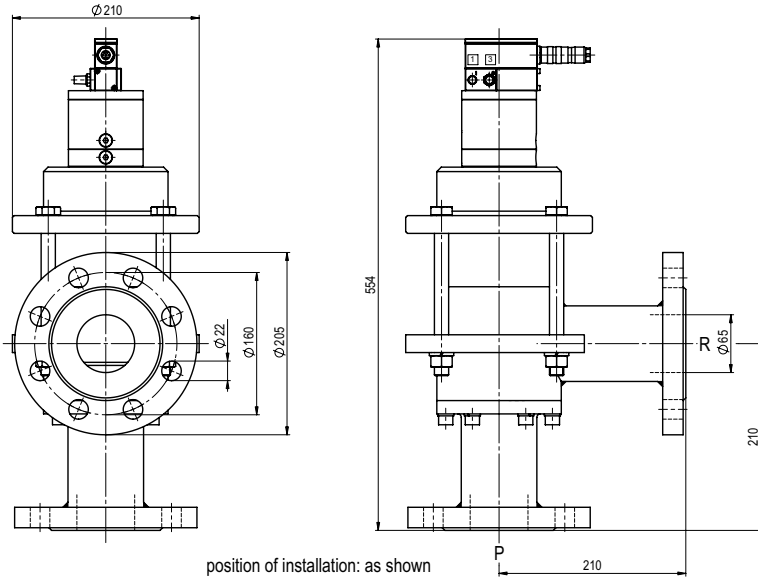

**actuation pressure-diagram**

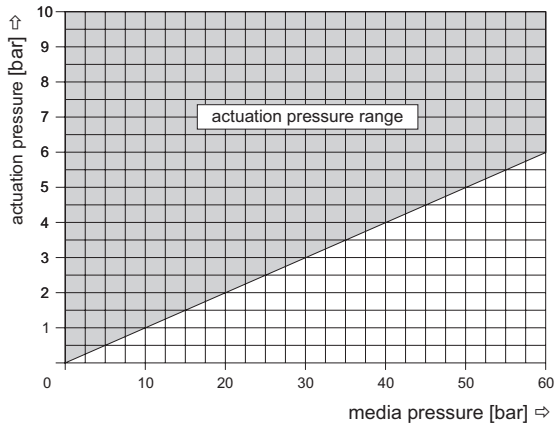

**pressureless circulation mode**

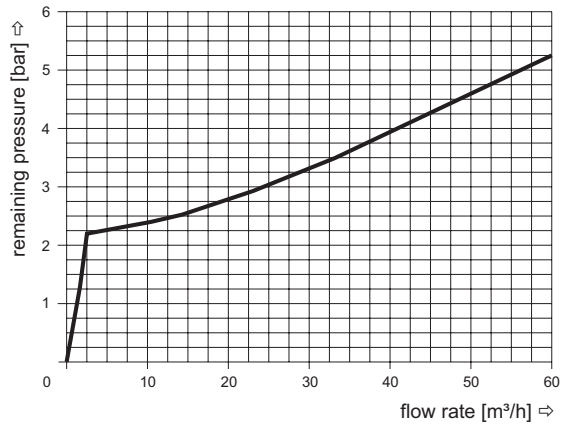

The application-specific layout relating to temperature, pressure conditions, switching behavior, media and its consistency may restrict the range of use or necessitate relevant modifications to materials used and seal arrangements.

Rights reserved to make technical alterations • Not responsible for printing errors • Detailed drawings can be obtained upon request