

# coaxial valve

## type MK 40 DR Ex FK 40 DR Ex

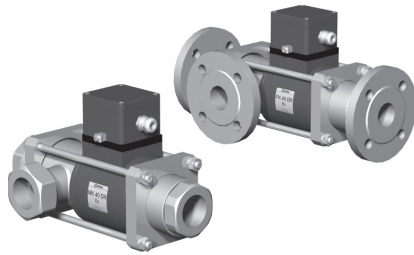

**3/2 way valve** **direct acting**  
**pressure range** PN 0-16 bar  
**orifice** DN 40 mm  
**connection** thread/flange  
**function** valve normally closed (A ► B) symbol **NC**  
 valve normally open (A ► B) symbol **NO**

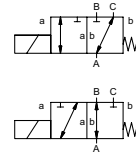

**△** Above stated body materials refer to the valve port connections that get in contact with the media only!

**design** pressure balanced, with spring return, intersecting switch-over  
**body materials** ① ② steel, galvanized  
 ③ ⑤ without non-ferr. metals  
 ④ steel, nickel plated ⑥ stainless steel  
**valve seat** synthetic resin on metal  
**seal materials** NBR PTFE, FPM, CR, EPDM

**details needed**

- orifice
- port
- function NC/NO
- operating pressure
- inlet pressure at A, B or C
- flow rate
- media
- media temperature
- ambient temperature
- nominal voltage

general specifications		options
<b>ports</b>	MK threads G 1 1/2 - G 2 FK flanges PN 16	special threads special flanges
<b>function</b>	NC	NO
<b>pressure range</b>	bar 0-16	
<b>Kv value</b>	m <sup>3</sup> /h 18,4 [A ⇒ B] 11,5 [A ⇒ C]	
<b>leak rate</b>		< 10 <sup>-6</sup> mbar·l·s <sup>-1</sup>
<b>pressure-vacuum</b>	P <sub>1</sub> ⇔ P <sub>2</sub>	upon request
<b>back pressure</b>	P <sub>2</sub> > P <sub>1</sub> see pressure range	
<b>media</b>	gaseous - liquid - highly viscous - gelatinous - contaminated	
<b>abrasive media</b>		upon request
<b>damping</b>	opening closing	
<b>flow direction</b>	see pressure range	
<b>switching cycles</b>	1/min 90	
<b>switching time</b>	ms opening 520 closing 150	
<b>media temperature</b>	°C DC: -20 to +40 AC: -20 to +40	
<b>ambient temperature</b>	°C DC: -20 to +40 AC: -20 to +40	
<b>limit switches</b>		inductive
<b>manual override</b>		available
<b>approvals</b>		LR/GL/WAZ
<b>mounting</b>		mounting brackets
<b>weight</b>	kg MK 18,5 FK 23,0	
<b>additional equipment</b>		upon request

**⚠** The valves' technical design is based on media and application requirements. This can lead to deviations from the general specifications shown on the data sheet with regards to the design, sealing materials and characteristics.

**⚠** If order or application specifications are incomplete or imprecise there exists a risk of an incorrect technical design of the valve for the required application. As a consequence, the physical and / or chemical properties of the materials or seals used, may not be suitable for the intended application.

electrical specifications		options
<b>nominal voltage</b>	U <sub>n</sub> 24 V DC	special voltage
	U <sub>n</sub> 230 V 40-60 Hz AC	special voltage
<b>actuation</b>	DC direct-current magnet	
	AC direct-current magnet with separate rectifier outside of the explosion-proof area	sand sealed rectifier
<b>insulation rating</b>	H 180°C	
<b>protection</b>	IP65	
<b>energized duty rating</b>	ED 100%	
<b>connection</b>	M16x1,5 terminal box	
<b>optional additional equipment</b>		
<b>current consumption</b>	U <sub>n</sub> V-DC 24 200	20 48 98 110 210 220 230
	I <sub>n</sub> A 2,05 0,29	2,72 1,07 0,54 0,48 0,25 0,25 0,21
<b>explosion proof</b>	II 2 G Eex me II T4 and II 2 D IP65 T 130°C PTB 03 ATEX 2051 X	
<b>limit switches</b>	inductive NAMUR	circuit amplifier

■ specifications not highlighted are standard  
 ■ specifications highlighted in grey are optional

# type MK 40 DR Ex

function: **NC**  
closed when not energized (A ► B)

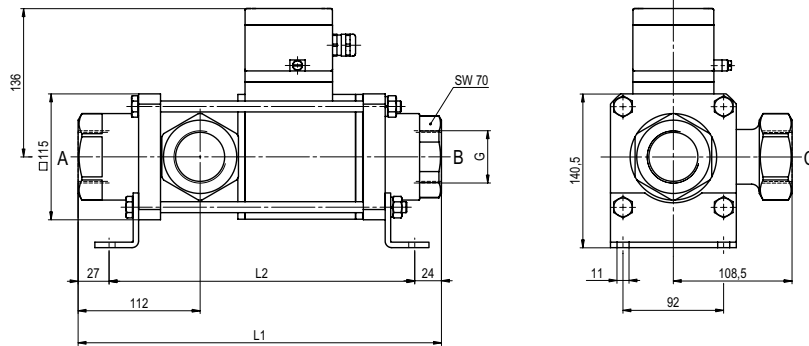

constructive length	L <sub>1</sub>	L <sub>2</sub>	L <sub>3</sub>
standard	332	281	394
with 1/2 inductive limit switches	373	322	435
with manual emergency (Hd)/ Hd and 1/2 ind. limit switches	373	322	435

flanges PN	DIN	øD	øk	ød
16	2633	150	110	18

# type FK 40 DR Ex

function: **NO**  
open when not energized (A ► B)

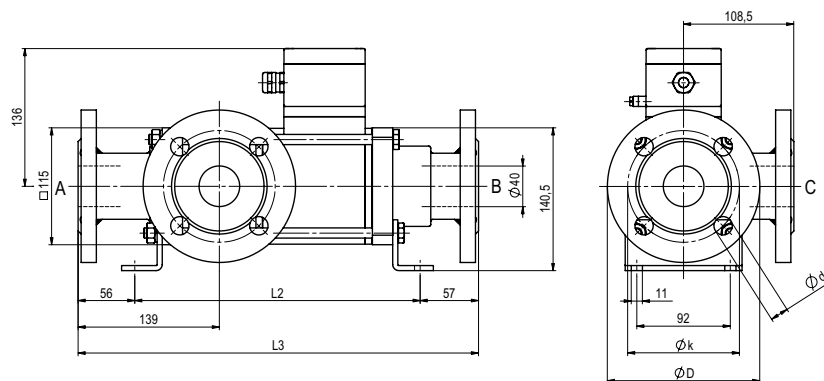

The application-specific layout relating to temperature, pressure conditions, switching behavior, media and its consistency may restrict the range of use or necessitate relevant modifications to materials used and seal arrangements.

Rights reserved to make technical alterations • Not responsible for printing errors • Detailed drawings can be obtained upon request