

coaxial valve

type MK 20 TÜV FK 20 TÜV

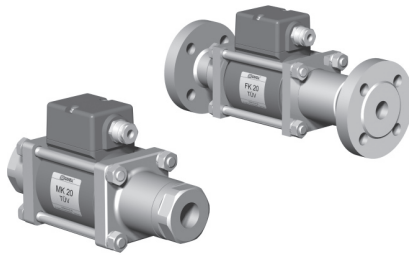

2/2 way valve direct acting
pressure range PN 0-40 bar
orifice DN 20 mm
connection thread/flange
function valve normally closed symbol **NC**
 valve normally open symbol **NO**

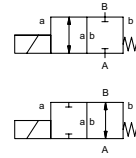

△ Above stated body materials refer to the valve port connections that get in contact with the media only!

design pressure balanced, with spring return
body materials ⑦ TÜV

valve seat synthetic resin on metal
seal materials FPM, PTFE

details needed

- orifice
- port
- function NC/NO
- operating pressure
- flow rate
- media
- media temperature
- ambient temperature
- nominal voltage

general specifications

options

ports	MK threads G 3/4 - G 1 1/4	
	FK flanges PN 40	
function	NC	NO
pressure range	bar 0-40	
Kv value	m ³ /h 7,4	
vacuum	leak rate	
pressure-vacuum	P ₁ ↔ P ₂	
back pressure	P ₂ > P ₁	available (max. 16 bar)
media	liquid fuels	
abrasive media		
damping	opening closing	
flow direction	A ↔ B as marked	
switching cycles	1/min 150	
switching time	ms opening 110 closing 110	
media temperature	°C DC: -10 to +140	
	AC: -10 to +140	
ambient temperature	°C DC: -10 to +60	
	AC: -10 to +60	
limit switches		mechanical
manual override		
approvals	TÜV DIN EN 264 + E DIN 32725	
mounting		mounting brackets
weight	kg MK 5,5 FK 7,5	
additional equipment		

electrical specifications

options

nominal voltage	U _n 24 V DC	
	U _n 230 V 40-60 Hz AC	
actuation	DC direct-current magnet	
	AC direct-current magnet with integrated rectifier	
insulation rating	H 180°C	
protection	IP65	
energized duty rating	ED 100%	
connection	M16x1,5 terminal box	
optional additional equipment		
current consumption	N-coil	
	H-coil 24 V DC 2,26 A	
	230 V 40-60 Hz AC 0,29 A	
explosion proof		
limit switches	mechanical	single pole double throw-SPDT

⚠ The valves' technical design is based on media and application requirements. This can lead to deviations from the general specifications shown on the data sheet with regards to the design, sealing materials and characteristics.

⚠ If order or application specifications are incomplete or imprecise there exists a risk of an incorrect technical design of the valve for the required application. As a consequence, the physical and / or chemical properties of the materials or seals used, may not be suitable for the intended application.

■ specifications not highlighted are standard
 ■ specifications highlighted in grey are optional

type MK 20 TÜV

function: **NC**
closed when not energized

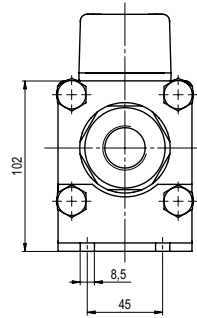
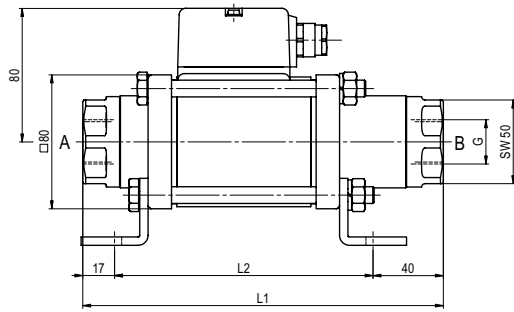

constructive length	L1	L2	L3
standard	215	158	269
with mechanical limit switches	235	178	289

type FK 20 TÜV

function: **NO**
open when not energized

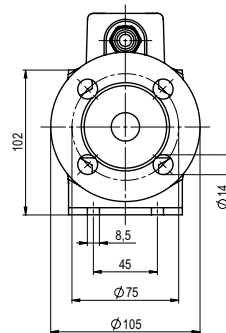
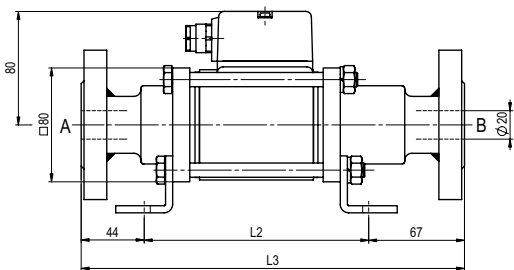

The application-specific layout relating to temperature, pressure conditions, switching behavior, media and its consistency may restrict the range of use or necessitate relevant modifications to materials used and seal arrangements.

Rights reserved to make technical alterations • Not responsible for printing errors • Detailed drawings can be obtained upon request